

Flood Light

Gas Station Canopy Light

Code: LEG-GS50 Series

Technical Data:

Product. Led gas station light (LEG-GS)
 Certification. CE, RoHS, IP67
 Warranty. 5 years
 Lamp body. Aluminum
 Light source. SINOCO patented LED
 Luminaire's Efficiency. 200Lm/W
 Driver. Mean well
 Beam angle. 45°, 60°, 90°, 120°
 Installation height. Ceiling mount
 Application. Gas station, parking lot etc.



Technical parameter

| Model | Power | Input voltage | Light Source | Luminous Flux | Luminaire's Efficiency | Product size | N.W | G.W | Packing (mm) |
|---------------|-------|-----------------------|----------------------|---------------|------------------------|---------------------|-------|-------|----------------------|
| LEG-GS50-40W | 40W | 100-277VAC 50-60HZ | SINOCO patented LEDs | 8000Lm | 200Lm/W | L450 * W450 * H30mm | 3.6kg | 4.5kg | L510 * W510 * H190mm |
| LEG-GS50-60W | 60W | 100-277VAC 50-60HZ | SINOCO patented LEDs | 12000Lm | 200Lm/W | L450 * W450 * H30mm | 3.7kg | 4.6kg | L510 * W510 * H190mm |
| LEG-GS50-90W | 90W | 100-277VAC 50-60HZ | SINOCO patented LEDs | 18000Lm | 200Lm/W | L450 * W450 * H30mm | 3.7kg | 4.6kg | L510 * W510 * H190mm |
| LEG-GS50-120W | 120W | 100-277VAC 50-60HZ | SINOCO patented LEDs | 24000Lm | 200Lm/W | L450 * W450 * H30mm | 4.5kg | 5.4kg | L510 * W510 * H190mm |



Dimension

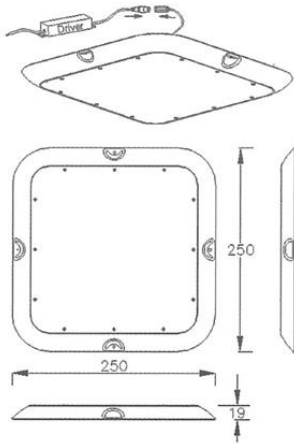

Type A
Ceiling Mounted
Power:30W

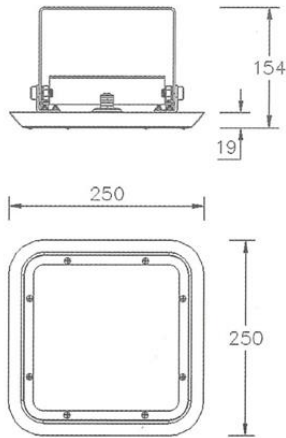

Type B
U-Bracket Surface Mounted
Power:30W

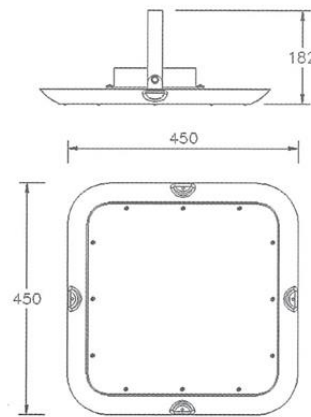

Type C
U-Bracket Surface Mounted
Power range:40-150W

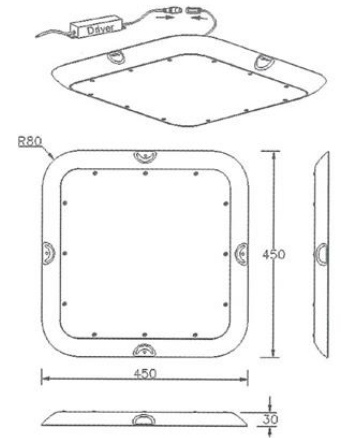

Type D
Ceiling Mounted
Power range:40-150W

Photometric Curve

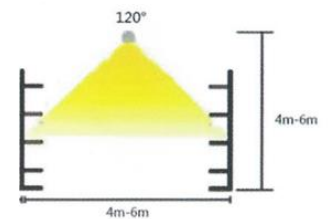
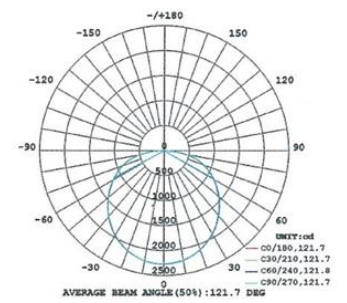
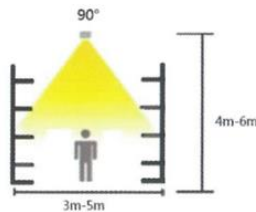
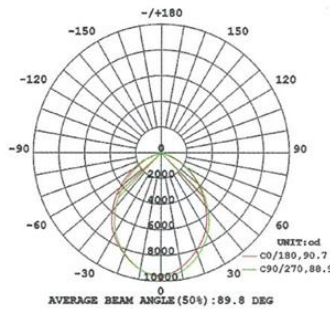
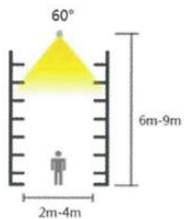
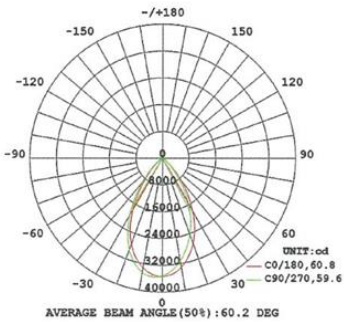

MOUNTING STEP

